



KAISER

Walking Mobile Excavator

S2



www.kaiser.li

**Top performance. Rugged design.
Superior technology. Maximum comfort.**



Natural stone wall construction, Switzerland



Torrent control, Austria



Forestry, Slovakia



Maintenance of swamps, Florida, USA



Emergency use in flood damage, Austria



Slope reinforcement, California, USA



Electric excavator, London



Steel fabrication/excavation, Austria



Ski piste construction, Bulgaria



Civil emergency assistance, China

Top performance

for versatile and flexible use

S2

From 9.8 t. The S2 is the ideal all-round machine for versatile use in difficult terrain. Obstacles such as slopes or river beds pose no problem – the S2 is ready for any challenge. The hydraulically adjustable legs offer optimal support. The steering wheels can be quickly removed for stability in extreme terrain. The Kaiser S2 is the most popular walking mobile excavator in the world and sets standards for high performance throughout the industry. The 2007 version has been further optimised to increase overall efficiency and performance.

Features

- Unattained lifting and slewing forces
- Fast and precise hydraulics
- Rugged steel construction
- Superior stability

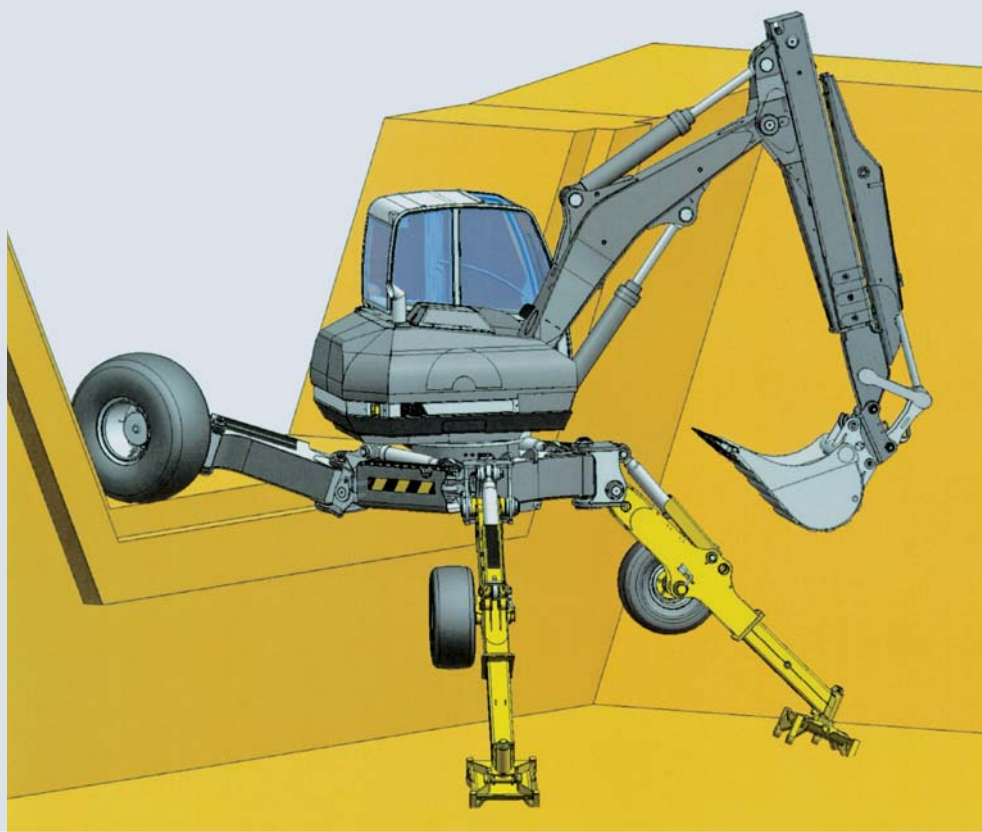
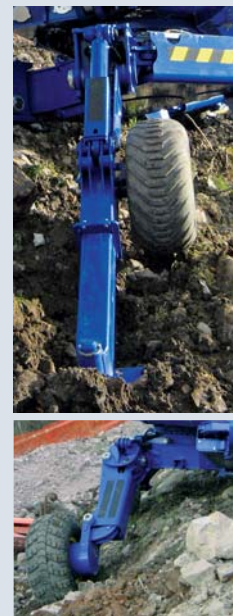

Exceptional climbing ability with maximum mobility



From 10.2 t. The special design of the S2 4x4 makes it ideal for working in difficult terrain where extra maximum mobility is required. The small front drive wheels add to enhance climbing ability with the hydraulically adjustable terrain pads ensuring maximum stability in all situations.

Features

- Maximum mobility in impassable terrain
- Permanent all-wheel drive
- Dual steering: wheel steering and leg steering
- Wide pad adjustment range for variable terrain adaptation
- Compact size for transportation



Multifunctional Carrier



From 10.9 t. The four large steerable front driving wheels are ideal for use above trenches or ditches, on the side of slopes on varying levels of terrain and in forests. All wheels are steerable over the total leg adjustment for exceptional mobility. Hydraulic lowerable pads offer excellent stability.

Features

- All-wheel steering for maximum manoeuvrability without compromising stability
- Triple steering: Leg and wheel steering front and rear
- Optimal driving and steering with permanent all-wheel drive
- Low ground pressure due to four large tyres
- Ideal gravity centre ensures optimal stability when using powerful attachments



The high performer for use in water and swamps



From 10.9 t. The special front-wheel steering enables efficient use in harsh swamp and marshland or water. Rolling resistance is low due to the special design of the legs. The machine can be raised for deep mudflats.

Features

- Low rolling resistance in rivers
- Triple steering: Leg and wheel steering front and rear
- Low ground pressure due to four large tyres
- Optimal driving and steering with permanent all-wheel drive
- Maximum stability on soft ground

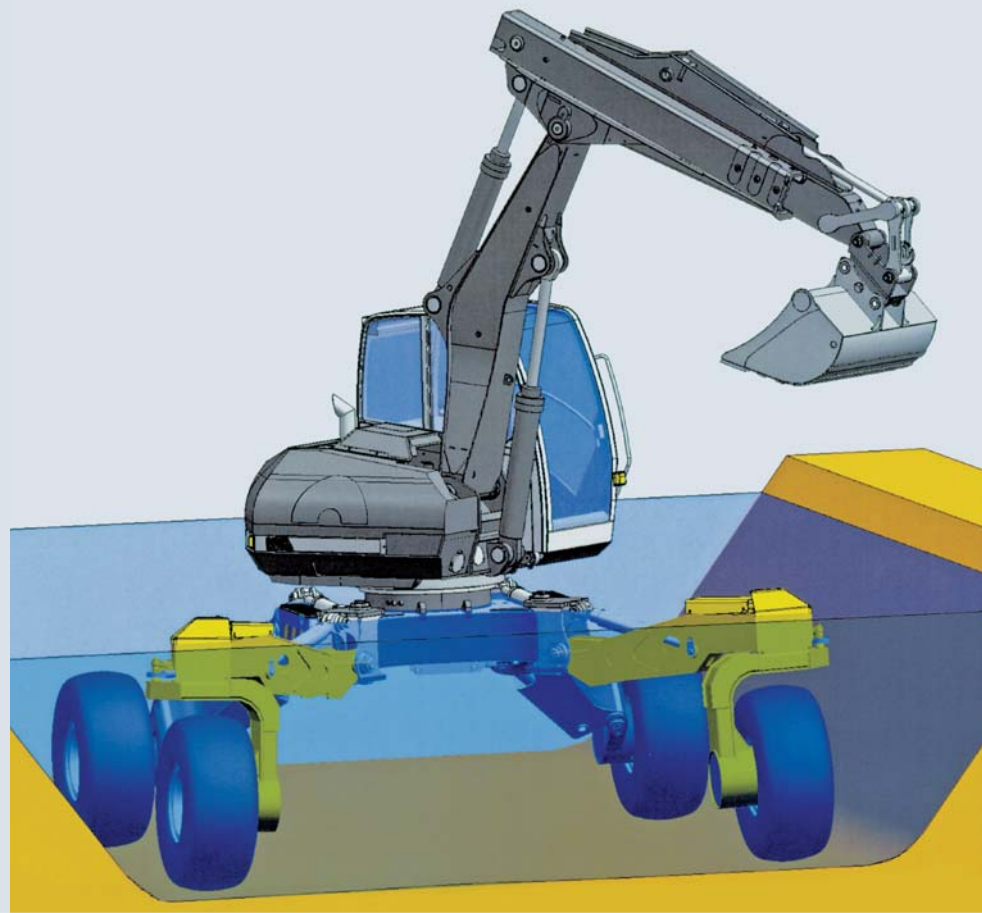

Equipment of S2 series

	S2	S2 4x4	S2 4x4 Cross	S2 4x4 Gator
Boom				
Hydraulic cylinder end position damping	●	●	●	●
Loose and fixed bearings with bushes	●	●	●	●
Load hook	●	●	●	●
Overload warning device, lifting gear I	●	●	●	●
Advertising boards	●	●	●	●
Boom working light	○	○	○	○
Hose support on boom	○	○	○	○
Lifting gear II	○	○	○	○
Drive				
Automatic brake for slewing drive	●	●	●	●
Powerful two-speed slewing drive	●	●	●	●
Slew torque control	●	●	●	●
Manual joystick controlled drive brake	●	●	●	●
Provision for rope winch	●	●	●	●
Two-speed 10km/h	○	●	●	●
Drive floor protection	○	○	○	○
All-wheel steering	○	○	○	○
Soft start rope winch	○	○	○	○
Approved for road traffic use CH	○	○	○	○
Cab				
ROPS cab	●	●	●	●
Air-suspension seat with high backrest	●	●	●	●
Safety belt	●	●	●	●
Safety shut-off lever for hydraulics	●	●	●	●
Emergency exit via front screen	●	●	●	●
Radio with CD	●	●	●	●
Sun visor	●	●	●	●
Foot rest	●	●	●	●
Ergonomic pedal position	●	●	●	●
Hydraulic joystick cross lever	●	●	●	●
Tool storage	●	●	●	●
Document pocket in driver's door	●	●	●	●
Interior lighting	●	●	●	●
Coat hook	●	●	●	●
Mobile phone socket 12 VDC	●	●	●	●
Socket 12 VDC	●	●	●	●
Cigarette lighter 12 VDC	●	●	●	●
Engine status indicators	●	●	●	●
Wiper with interval wash/wipe	●	●	●	●
Washer/wiper system	●	●	●	●
Cab tilting device (one-hand operation)	●	●	●	●
Seat with vertical/horizontal damping	○	○	○	○
Lighting and mirrors	○	○	○	○
Roof guard with lamp protection FOPS	○	○	○	○
Air conditioning	○	○	○	○
Weather-protection roof	○	○	○	○
Flashing light	○	○	○	○
Bottom windscreen guard	○	○	○	○
Superstructure				
Antislip coatings	●	●	●	●
Soundproofing	●	●	●	●
Maintenance-free batteries	●	●	●	●
Tools	●	●	●	●
Special paint finish I - coverings	○	○	○	○
Special paint finish II - entire machine	○	○	○	○
Central lubrication	○	○	○	○

	S2	S2 4x4	S2 4x4 Cross	S2 4x4 Gator
Hydraulics				
Rotation crown wheel pinion lubrication	●	●	●	●
Fan management	●	●	●	●
Mineral oil	●	●	●	●
Biodegradable hydraulic oil	○	○	○	○
Fine filtration/water separator	○	○	○	○
Engine				
Electronically controlled (Common Rail)	●	●	●	●
Aftercooler	●	●	●	●
Water cooler	●	●	●	●
Diesel cooler	●	●	●	●
Fuel water separator	●	●	●	●
Cold start system	●	●	●	●
Reserve diesel tank 296 Lt	●	●	●	●
Electric diesel refuelling pump	●	●	●	●
Particle filter	○	○	○	○
Front tyres				
385/45-14.25	●	-	-	-
15.5/55R18MPT 14 Pr	-	●	-	-
400/55-17.5	○	○	-	-
52x20.5-20	-	-	●	●
500/60-22.5	-	○	○	-
600/55-22.5	-	○	○	-
600/55-26.5	-	○	○	-
Rear tyres				
52x20.5-20	●	●	●	●
500/60-22.5	○	○	○	○
600/55-22.5	○	○	○	○
600/55-26.5	○	○	○	○
Equipment				
Joint pad	○	○	○	-
Street pad	○	○	○	-
Preparation Quick-changer "Blitz"	○	○	○	○
Preparation Quick-changer "Rotorblitz"	○	○	○	○

● Series ○ Option - not available

Dealer Stamp:

223042007 Technical changes are possible without further notice!

www.kaiser.li

KAISER Aktiengesellschaft
Fahrzeugwerk
LI-9486 Schaanwald
Tel. +423-377 21 21
Fax +423-377 21 10
kaiserag@kaiser.li



KAISER